

# POWER CUBE SA/80 series

## FEATURES / BENEFITS

- High Power output
- High level of performance with minimal operating costs
- Automatic tracking and best optimization to load
- Constant, repeatable power generation via microprocessor control
- Minimum cooling water flow required
- High Safety: output insulation from the mains
- Embedded digital electricity meter
- Highly integrated with a small footprint
- User Friendly Operations through graphical touch-screen interface
- Stainless Steel casing
- Compliant with Electrical Safety and Electromagnetic Compatibility Regulations

ENERGY SAVER



► Power Cube 100-SA/80 Generator

## SA/80 series

- **25-SA/80 GENERATOR** 25 kW
- **50-SA/80 GENERATOR** 50 kW
- **75-SA/80 GENERATOR** 75 kW
- **100-SA/80 GENERATOR** 100 kW



► Scan this code to get more info



www.ceia.net

CEIA reserves the right to make changes, at any moment and without notice, to the models (including programming), their accessories and options, to the prices and conditions of sale



## POWER CUBE SA/80 series

The 100, 75, 50, 25 kW Green Generators

**The New SA/80 Generator Series** is a high power Induction unit in a very compact size with embedded advanced microprocessor based control software and state-of-the-art electronics. This allows **very high efficiencies (>96%) under a wide variety of workload conditions** while maintaining precise, stable and repeatable output power.

### SA/80 GENERATORS SERIES WITH 100, 75, 50 AND 25 KW POWER

For more than 30 years CEIA has been manufacturing Inductive Heating Systems, achieving great experience in the field, and carrying out continuous R&D activities.

The SA/80 Generators and Network Matching [Heating Head] hardware design combined with a state-of-the-art power and control electronics allow an extremely high conversion efficiency and therefore a high reliability and low operating costs.

The embedded microprocessor control system is based on a wide feedback signals network, that allows a fine coil voltage and current control, and guarantees the consistency and accuracy of output power generation, suitable for highly repeatable production processes.

All the CEIA Generators are equipped with an isolation transformer that separates the coil output from the power supply line guaranteeing a high level of operator safety.

### AUTOMATIC OUTPUT MATCHING TO WIDE LOAD IMPEDANCE

The SA/80 Generators adaption system to the load is fully automatic. The operator does not have to carry out any type of mechanical operation on the Generator or on the Heating Head. The Autolearn function provides a fully automatic process for selecting the best Generator parameters, maximizing conversion efficiency at each set point power. This reduces the set up time and associated costs.

Furthermore, during operation, a continuous and real time automatic tracking of output matching is carried out in order to always meet the set point power even in case of workload condition changing. [i.e. heating temperature over curie point]. This provides for the greatest possible efficiency during the entire heating cycle.

The new SA Series Generators are therefore ideal for industrial production processes, where the maximum reliability, repeatability and output power accuracy are required together with wide load matching flexibility, fast set-up and low operation costs.

### FRIENDLY HUMAN MACHINE INTERFACE

A wide 7" high-resolution touch screen panel allows the operator to access programming function parameters quickly.

All the process parameters are continuously displayed on the Main screen:

- Coil Voltage
- Coil Current
- Output Power Setting and Real time Reading
- Temperature Setting and Real time Reading
- Cooling Water Temperature and Flow
- Working Cell [Recipe]
- Generator Status [Alarm]

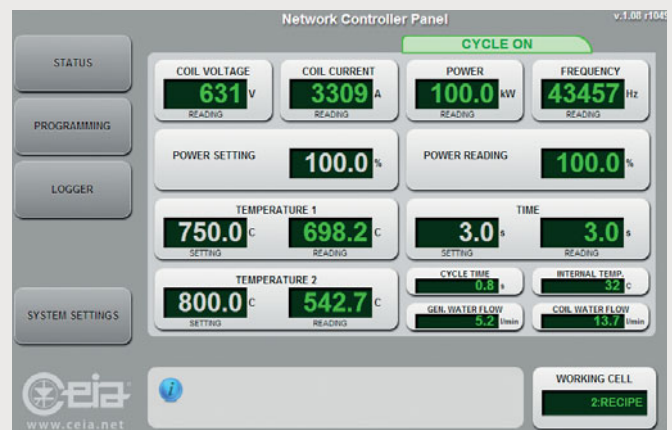

► Main screen

**The Autolearn function provides a fully automatic process for selecting the best Generator parameters, maximizing conversion efficiency at each set point power.**

**INTEGRATED WEB SERVER AND DATA LOG SYSTEM**

- Integrated Webserver with 2-port 100base-T Ethernet switch
- No client software required, only a web browser
- Zero configuration network for simple setup
- Built-in Rich Internet Application (RIA) for Status Monitoring, Remote Programming, Logging and Thermal Profile Management
- Internal storage capacity for more than 100,000,000 data samples

The SA/80 series is equipped with integrated Data Log and Web Server system. It is possible to perform automatic data storage, for a proper process quality control, monitoring heating temperatures, output power, frequency, voltage and inductor current. An Ethernet TCP/IP port allows access to the internal web server of the Generator for remote programming settings and interface with SCADA / DCS systems.

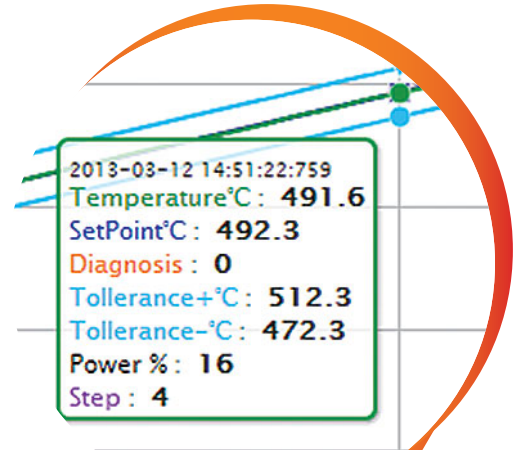

► Data Logger screen

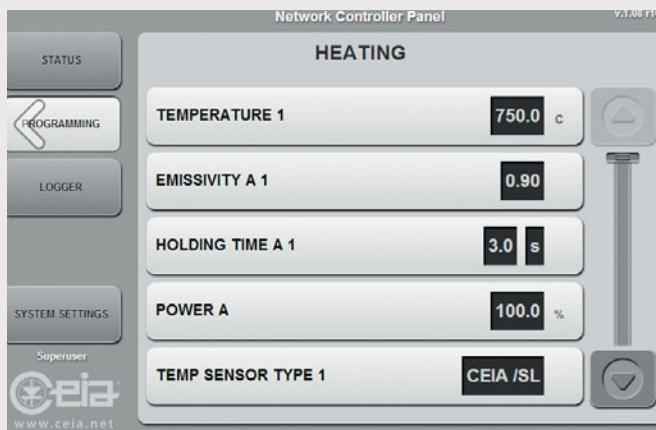

► Heating menu

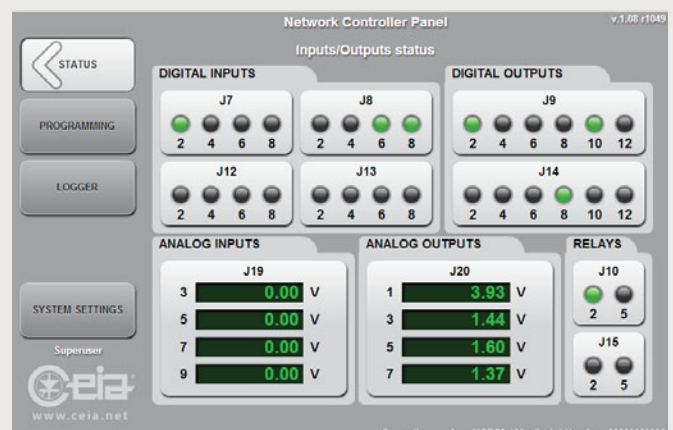

► Input/Output Status

## POWER CUBE SA/80 series

The 100, 75, 50, 25 kW Green Generators

Thanks to the **Thermal Profile Monitoring software**, coupled with the CEIA SH15/SLE Optical Pyrometers, the user is now able to set specific temperature profiles, monitor and certify the heating process of each production item.

### THERMAL PROFILE MANAGEMENT AND MONITORING

- Up to 20 Programmable Temperature and Time Segments per Process
- Up to 100 different storable processes
- Maximum Power Output Programmable for Each Individual Segment
- Temperature Tolerance Window Programmable for Each Individual Segment
- Out-of Tolerance and End-of-Cycle Outputs for Each Process

The new Generators are excellent for all traditional heat treatment applications such as brazing, forging, annealing, and also for all continuous heating cycle applications, where accurate control of the process parameters and stable and constant output supply Generator power are required.

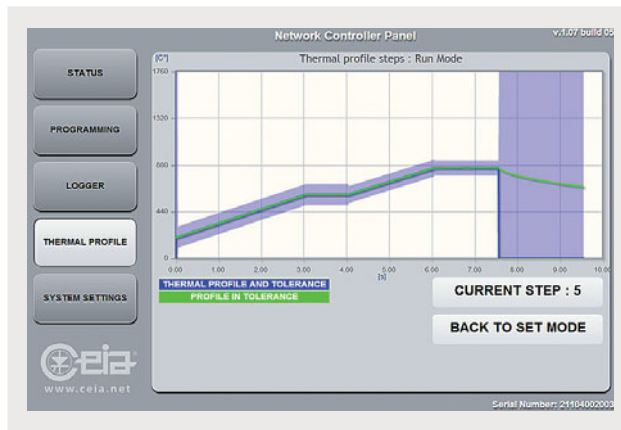

► Real-time Thermal Profile screen

### FIELD BUS MANAGEMENT

- Management and control of the heating process via Field Bus protocol:
  - Profinet
  - EtherCAT
  - EtherNet / IP
  - Others upon request (DeviceNet, Profibus, CANopen, CC-Link, CompoNet, ControlNet, Modbus-RTU or TCP, SERCOS III)
- Field Bus and Network compliance certification available upon request

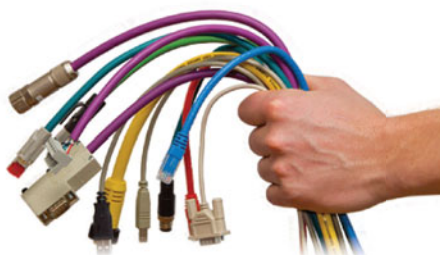
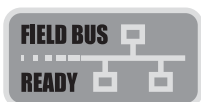

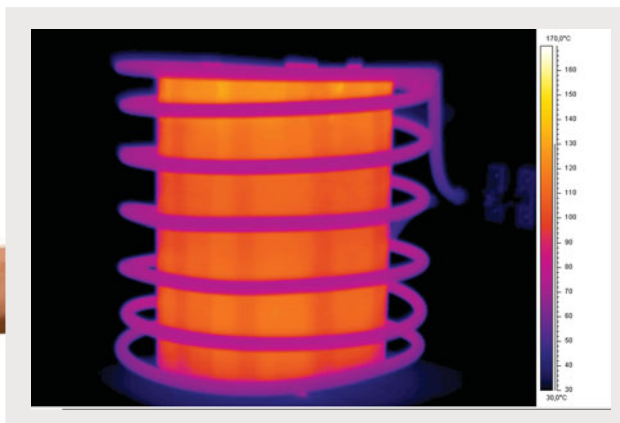

### THERMOCAMERA CONTROL

- Interface with Thermocamera via a direct Ethernet connection on the Controller
- Management of up to two independent zones of interest (ROI # 1 and ROI # 2).
- Ideal for temperature control on large surfaces or in applications where the location of the hot spot moves during the heating process (Max Temperature Spot Automatic Tracking)
- Simultaneous measurement and control of two different areas used to prevent over heating



The **Field Bus** allows **connection to a PLC** or other external logic for activation, inhibition, control of the output power, the operational status of the generator and any excursion from the thresholds of the thermal profile set.

### MATCHING NETWORK SPECIFICATIONS

HEATING HEAD*		Capacity [uF]	Output Power [kVAR]	Dimensions in mm [W x L x H]	Weight [Kg]	IP Protection Degree
PWH-5000		19 - 42	5000	336 x 328 x 266	34	IP55
PWH-2500		14	2500	206 x 328 x 256	24	IP55
PWH-1250		8-16	1250	120 x 285 x 200	15	IP55

\* Inductors shown in the pictures as example only

TYPICAL APPLICATION	GENERATOR			
	100-SA/80	75-SA/80	50-SA/80	25-SA/80
MAGNETIC METALS i.e. Carbon Steel C40, C45, AISI 420, Nickel		PWH-2500		PWH-1250
NON MAGNETIC METALS AND GRAPHITE i.e. Stainless Steel, Aluminum, Brass, Copper		PWH-5000		PWH-2500

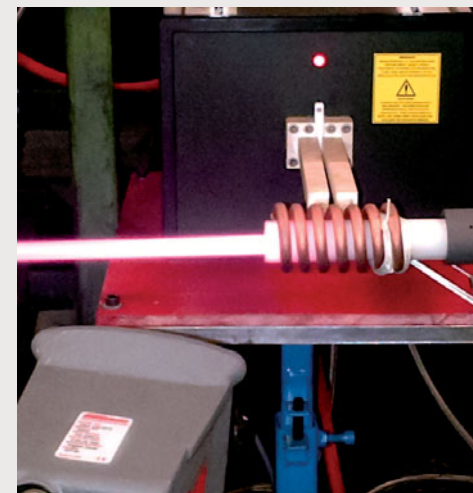
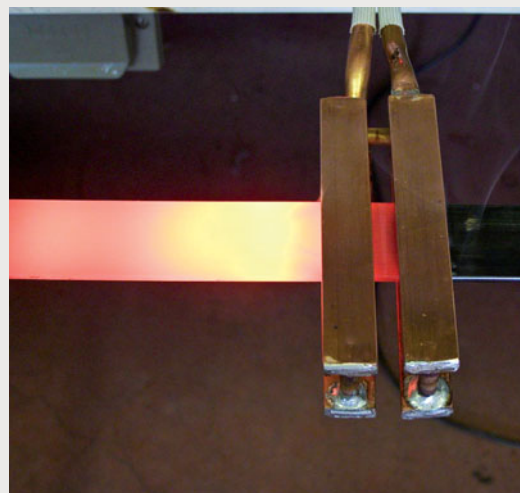
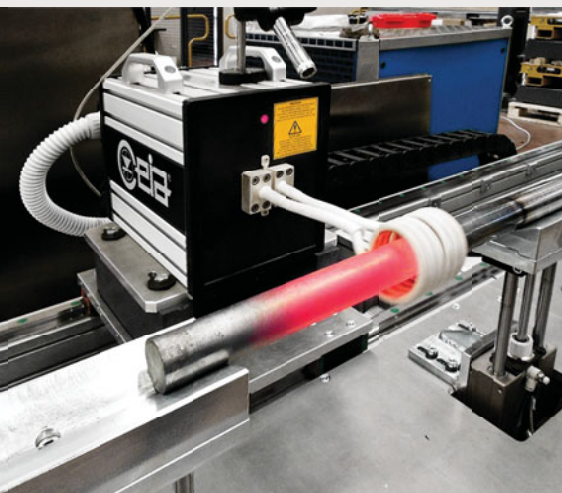

# POWER CUBE SA/80 series

The 100, 75, 50, 25 kW Green Generators

## HEATING HEADS DIMENSIONS [mm]

### PWH-1250 HEATING HEAD

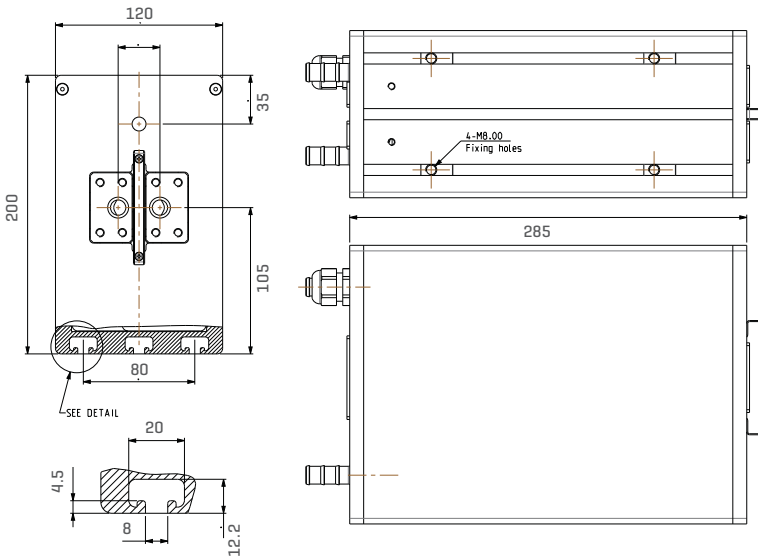

### PWH-2500 HEATING HEAD

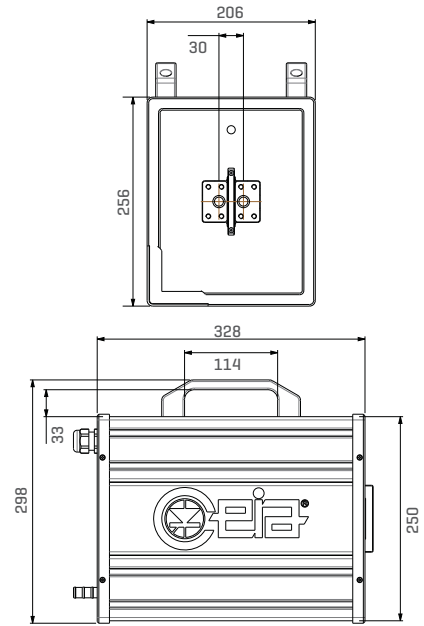

### PWH-5000 HEATING HEAD

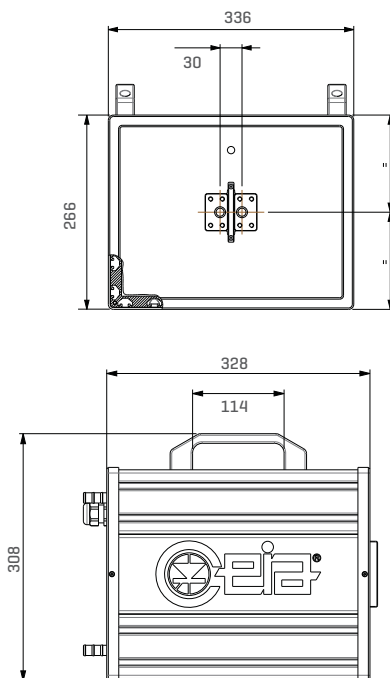



► Power Cube 50-SA/80

## GENERATORS DIMENSIONS [mm]

### 25-SA/80 and 50-SA/80 GENERATORS

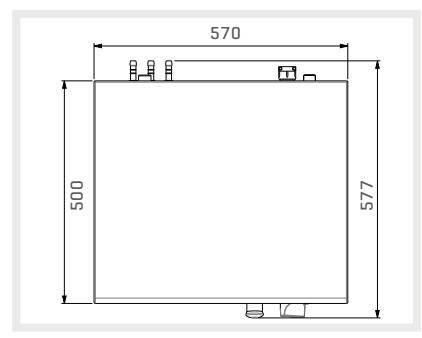
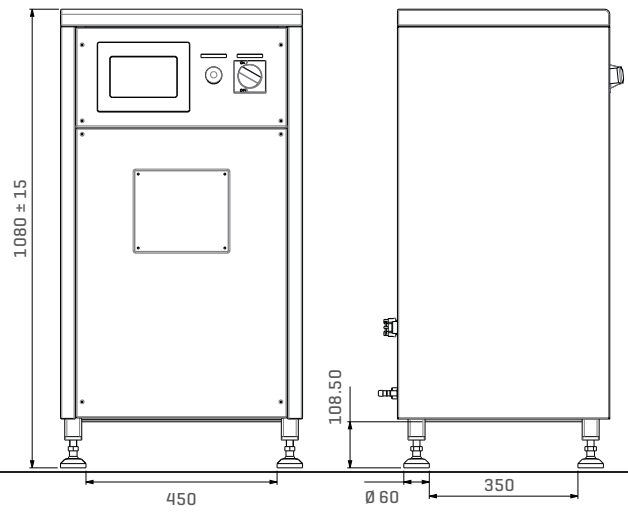

► Top view

### 75-SA/80 and 100-SA/80 GENERATORS

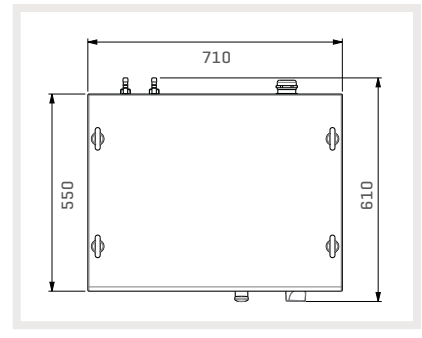
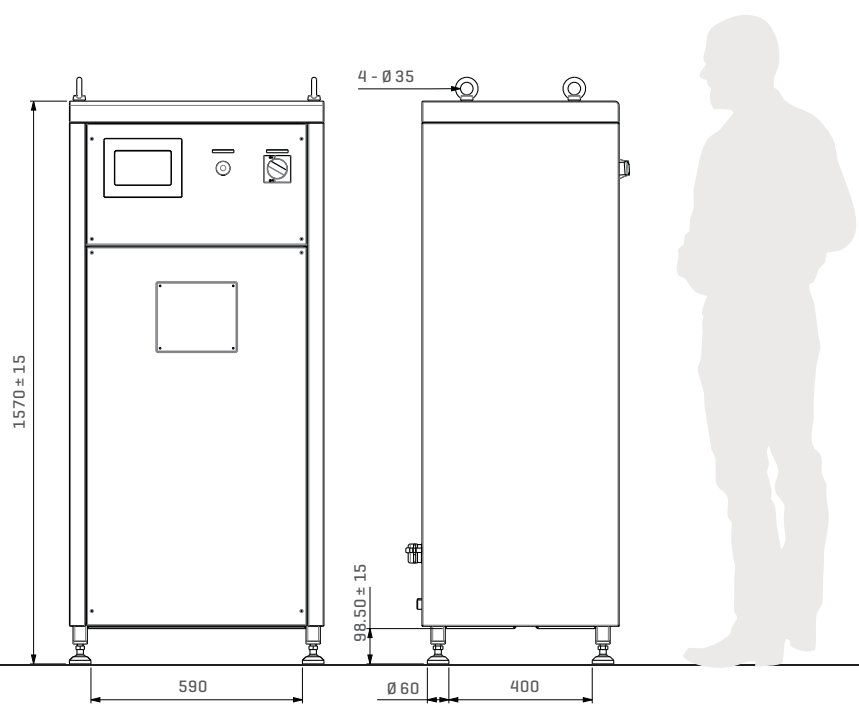

► Top view



# SH/SLE Compact Optical Pyrometers

Compact Pyrometers for Measurement of metallic surfaces  
between **80°C** and **2200°C**

## SH/SLE series

- ▶ **SH15/SLE**  
SINGLE-COLOR SERIES **80°C TO 2000°C**
- ▶ **SH2C/SLE**  
DUAL-COLOR SERIES **600°C TO 2200°C**

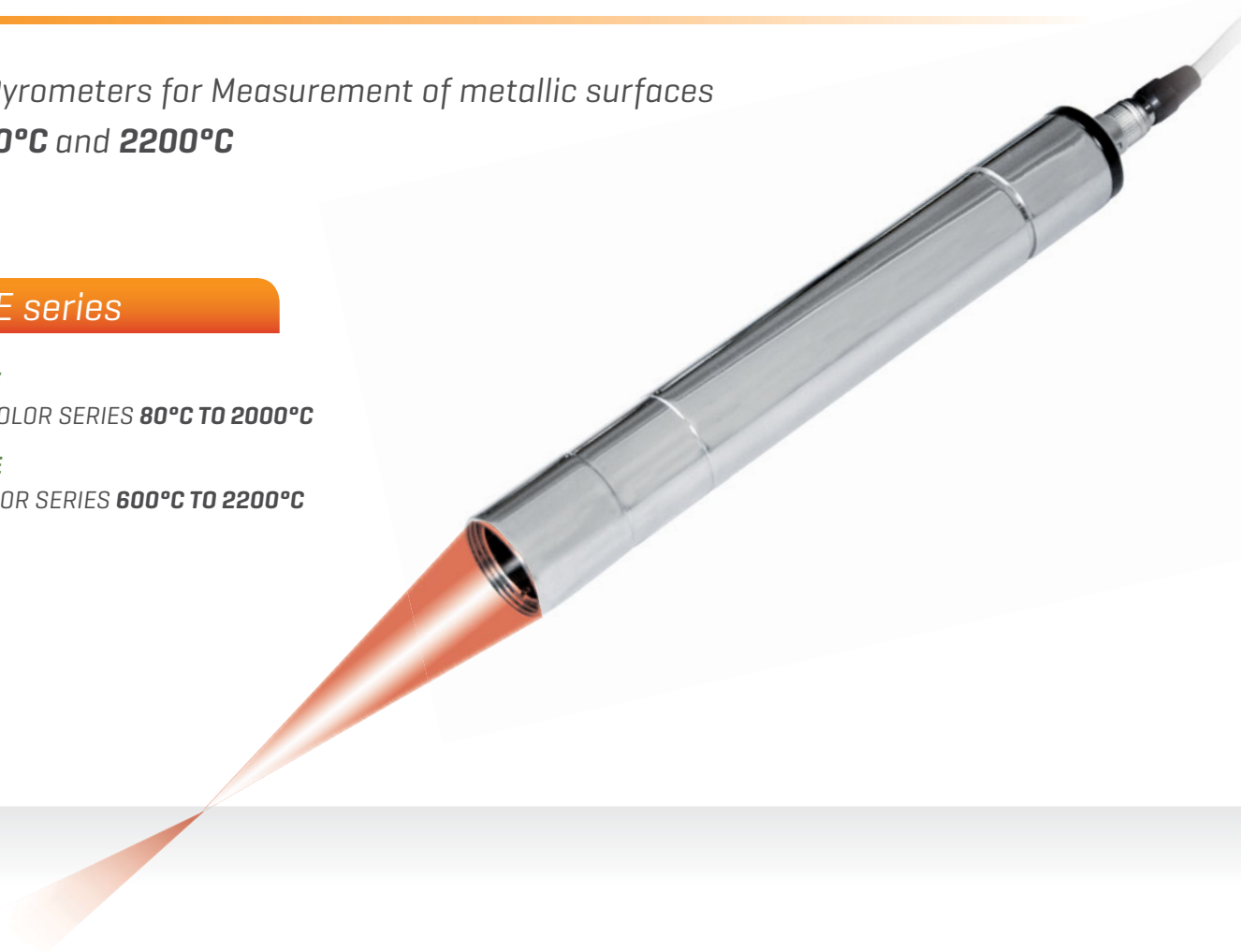

## FEATURES

- Emissivity adjustable from 0.1 to 1 [SH15/SLE series]
- Temperature measurement independent from metal emissivity [SH2C/SLE series]
- High Accuracy
- High-Speed
- Very Compact design
- Available with different focus distance and aiming spot size
- LED aiming light
- Supplied with Calibration Report traceable to Certified International Standards
- AISI 304 Stainless Steel Construction

**The SH/SLE sensors allow high quality management of the heating process according to the set temperature values. The reduced overall dimensions allow an easy integration of the pyrometer in automatic production systems.**

*Up to two optical sensors for temperature measurement can be connected to the generator.*

### SH/SLE PYROMETERS SELECTION

- ▶ **SH15/SLE-550-D1** 80... 700°C
- ▶ **SH15/SLE-550-D2** 120... 900°C
- ▶ **SH15/SLE-550-D3** 200... 1600°C
- ▶ **SH15/SLE-550-D4** 500... 2000°C
- ▶ **SH2C/SLE** 300... 2200°C

▶ CEIA SH/SLE Pyrometer mounted on ES3M micrometric optical sensor base.



	SH15/SLE	SH2C/SLE	
		Single-color mode	Dual-color mode
TEMPERATURE RANGE	80... 2000°C	300... 2200°C	600... 2200°C
TEMPERATURE RESOLUTION	0.1 °C (up to 999.9 °C) 1 °C (above 1000 °C)	0.1 °C (up to 999.9 °C) 1 °C (above 1000 °C)	0.1 °C (up to 999.9 °C) 1 °C (above 1000 °C)
EMISSIVITY RANGE	0.1-1.0	0.1-1.0	N/A
READING SPOT DIAMETER	see table	see table	see table
FOCUS DISTANCE	see table	see table	see table
RESPONSE TIME	100 µs Time Constant		
UNCERTAINTY	± 0,3% of reading in °C. All Pyrometers are supplied with calibration report traceable to certified International Standards		
MEASUREMENT SPOT AIMING	High Definition, 620 nm wavelength led beam		
INTERNAL DIGITAL CONTROLS	Offset and Range Calibration Parameters Environmental Temperature Measurement and Correction Automatic Gain Range Selection		
POWER SUPPLY	+/-15 V - +10/-5 mA, directly supplied by CEIA Controllers		
CONNECTION CABLE	Diameter 4.8 mm x Length 5 ... 1.5 ... 4 m		
HOUSING	AISI 304 Stainless Steel		
WEIGHT	100 g		
HOUSING PROTECTION CLASS	IP65		
OPERATING TEMPERATURE	0 °C to + 65 °C		
STORAGE TEMPERATURE	- 25 °C to + 70 °C		
CONFORMITY	Complies with international standards currently applicable for Electrical Safety and Electromagnetic Compatibility (EMC)		

### MODEL CONFIGURATION AND OPTICS DATA

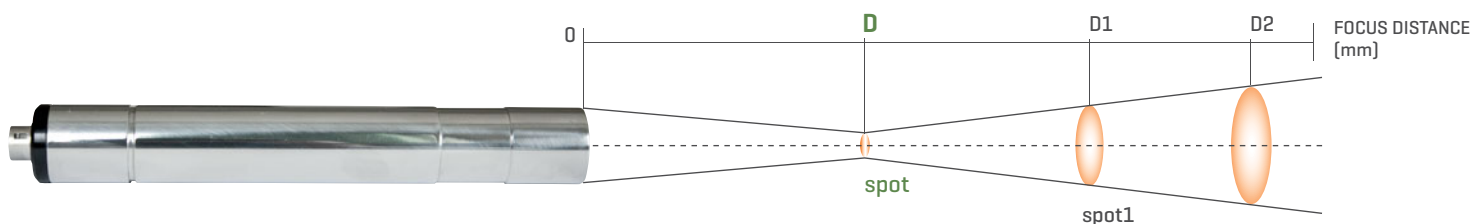

MODEL	Close-up lens	D distance (mm)	Spot diameter (mm)	D1 distance 1 (mm)	Spot 1 diameter (mm)	D2 distance 2 (mm)	Spot 2 diameter (mm)
SH15/SLE-550-D1 80... 700°C	Included	550	12.5	1000	36	2000	86
	CL240/SH15	240	4.5	500	24	1000	63
	CL120/SH15	120	2.5	250	19	500	52
	CL60/SH15	60	0.5	150	18.5	300	51
SH15/SLE-550-D2 120... 900°C	Included	550	4.5	1000	21	2000	57
	CL240/SH15	240	1.5	500	18	1000	51
	CL120/SH15	120	1	250	17	500	46
	CL60/SH15	60	<0.4	150	19	300	50
SH15/SLE-550-D3 200... 1600°C	Included	550	2	1000	16.5	2000	47
	CL240/SH15	240	0.6	500	16	1000	47
	CL120/SH15	120	<0.4	250	15	500	44
SH15/SLE-550-D4 500... 2000°C	Included	550	2	1000	16.5	2000	47
	CL240/SH15	240	0.6	500	16	1000	47
	CL120/SH15	120	<0.4	250	15	500	44
SH2C/SLE 300... 2200°C	Included	550	12.5	1000	36	2000	86
	CL240/SH15	240	4.5	500	24	1000	63
	CL120/SH15	120	2.5	250	19	500	52

### DIMENSIONS

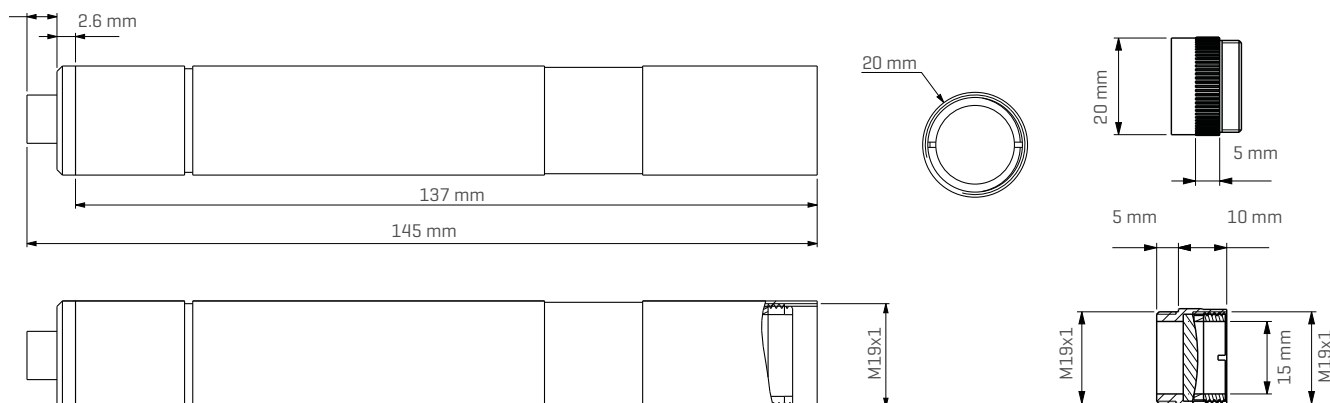

## ACCESSORIES

		Description	Focus distance	Code
		CLOSE-UP LENS SH15-FOCUS	240 mm	CL240/SH15
			120 mm	CL120/SH15
			60 mm	CL60/SH15
		COOLING JACKET UNIT WITH INTEGRATED AIR PURGE		SLE-PURGE-COOL
		90° VIEW MIRROR SYSTEM		SLE-90D-BD
		AIR PURGE UNIT		SLE-PURGE
	FOR SH15/SLE	CONNECTION CABLE	LENGTH: 1.5 m	49438
			LENGTH: 4 m	49439
	FOR SH2C/SLE		LENGTH: 1.5 m	63272
			LENGTH: 4 m	63273
		ES3M MICROMETRIC OPTICAL SENSOR BASE		23497
		SH23 OPTICAL SENSOR BASE		21871

### SH15/SLE MODEL APPLICATIONS

- ANNEALING
- BONDING
- BRAZING
- CAP SEALING
- CURING
- FORGING
- HARDENING
- HOT FORMING
- LOCALIZED HEATING
- MELTING
- METAL GLASS
- SEALING
- NORMALIZING
- PREHEATING
- SINTERING
- SHRINK FITTING
- TEMPERING
- TIN SOLDERING

### SH2C/SLE MODEL APPLICATIONS

- HARDENING, FORGING, BRAZING, SOLDERING
- NOBLE METALS MELTING AND PURIFYING
- WIRE/ROD MILL
- SILICON PROCESSING
- GLASS INDUSTRY - GOB TEMPERATURE MEASUREMENT
- CEMENT INDUSTRY - CLINKER TEMPERATURE IN ROTARY KILNS

# POWER CUBE SA/80 series

## TECHNICAL DATA

		25-SA/80	50-SA/80	75-SA/80	100-SA/80
POWER SUPPLY AND POWER	Max. absorbed power	25 kW	50 kW	75 kW	100 kW
	Max. power at inductor	2000 kVAR (depends on type of head and inductor used)	3000 kVAR (depends on type of head and inductor used)	4000 kVAR (depends on type of head and inductor used)	5000 kVAR (depends on type of head and inductor used)
	Power supply	400 V~ ±10%, three-phase - 50 Hz / 60 Hz, no neutral			
	Input current	45A max; external conductors 10 mm <sup>2</sup> (min)	85A max; external conductors 16 mm <sup>2</sup> (min)	130A max; external conductors 50 mm <sup>2</sup> (min)	170A max; external conductors 70 mm <sup>2</sup> (min)
FREQUENCY RANGE		25 kHz... 100 kHz			
COOLING	Water cooling system	Direct off-take from mains at recommended pressure of approx. 4 bar (min. 2 bar, max. 6 bar). Minimum flow rate: • Generator: 2,5 liters per minute. • Heating coil: from 3 to 10 liters per minute, depending on the coil used. Water temperature at inlet: from ambient temperature to 45°C (non condensing)	Direct off-take from mains at recommended pressure of approx. 4 bar (min. 2 bar, max. 6 bar). Minimum flow rate: • Generator: 2,5 liters per minute. • Heating coil: from 5 to 20 liters per minute, depending on the coil used. Water temperature at inlet: from ambient temperature to 45°C (non condensing)	Direct off-take from mains at recommended pressure of approx. 4 bar (min. 2 bar, max. 6 bar). Minimum flow rate: • Generator: 3 liters per minute. • Heating coil: from 8 to 25 liters per minute, depending on the coil used. Water temperature at inlet: from ambient temperature to 45°C (non condensing)	Direct off-take from mains at recommended pressure of approx. 4 bar (min. 2 bar, max. 6 bar). Minimum flow rate: • Generator: 3 liters per minute. • Heating coil: from 8 to 30 liters per minute, depending on the coil used. Water temperature at inlet: from ambient temperature to 45°C (non condensing)
	Electric chiller system	Power: ≥ 5 kW Water flow rate: 0,3 ÷ 0,8 m <sup>3</sup> /h Pressure: 3.5 bar - 5 bar	Power: ≥ 10 kW Water flow rate: 0,5 ÷ 1,5 m <sup>3</sup> /h Pressure: 3.5 bar - 5 bar	Power: ≥ 15 kW Water flow rate: 0,7 ÷ 2,0 m <sup>3</sup> /h Pressure: 3.5 bar - 5 bar	Power: ≥ 20 kW Water flow rate: 1,0 ÷ 2,5 m <sup>3</sup> /h Pressure: 3.5 bar - 5 bar
OPERATING MODE		Continuous operation			
CONTROL MODE		Automatic (controlled by a CEIA control and monitoring unit)			
CONTROL AND MONITORING		Automatically stabilized heating power (not influenced by power supply voltage variations)			
SELF-DIAGNOSTICS	Visual and acoustic fault signal	Cooling water temperature and pressure monitoring			
		Short-circuits between inductor leads			
		Internal fault			
		Inductor dimensioning monitoring			
		Heating head connection monitoring			
		Power supply voltage value monitoring			
OPERATING CONDITIONS	Operating temperature	+ 5 °C to + 55 °C			
	Storage temperature	- 20 °C to + 70 °C			
	Relative humidity	0 – 95% (non condensing)			
IP PROTECTION DEGREE		IP54			
WEIGHT		132 Kg	160 Kg	270 Kg	300 Kg
SAFETY FEATURES	Galvanic insulation from the mains supply voltage				
	Complies with international standards currently applicable for Electrical Safety (EN 60204-1) and Electromagnetic Compatibility (EN 61000-6-2, EN 61000-6-4)				



COSTRUZIONI ELETTRONICHE INDUSTRIALI AUTOMATISMI

Zona Ind.le 54/G, 52041 Vicinaggio - Arezzo (ITALY)

Tel. +39 0575-4181 Fax +39 0575-418287 E-mail: powercube@ceia-spa.com

www.ceia.net

CEIA reserves the right to make changes, at any moment and without notice, to the models, their accessories and options, to the prices and conditions of sale

DP040K0013v5000UK-67301

